

**ELECTRONICS AND TELECOMMUNICATION
ENGINEERING**

Paper – I

Time Allowed : **Three Hours**

Maximum Marks : **300**

Question Paper Specific Instructions

Please read each of the following instructions carefully before attempting questions :

There are **EIGHT** questions divided in **TWO** sections.

Candidate has to attempt **FIVE** questions in all.

Questions No. **1** and **5** are **compulsory** and out of the remaining, **THREE** are to be attempted choosing at least **ONE** question from each section.

The number of marks carried by a question / part is indicated against it.

Wherever any assumptions are made for answering a question, they must be clearly indicated.

Diagrams / figures, wherever required, shall be drawn in the space provided for answering the question itself.

Unless otherwise mentioned, symbols and notations carry their usual standard meanings.

Attempts of questions shall be counted in sequential order. Unless struck off, attempt of a question shall be counted even if attempted partly.

Any page or portion of the page left blank in the Question-cum-Answer Booklet (QCA) must be clearly struck off.

Answers must be written in **ENGLISH** only.

Values of constants which may be required :

Electron charge	= -1.6×10^{-19} Coulomb
Free space permeability	= $4\pi \times 10^{-7}$ Henry/m
Free space permittivity	= $(1/36\pi) \times 10^{-9}$ Farad/m
Velocity of light in free space	= 3×10^8 m/sec
Boltzmann constant	= 1.38×10^{-23} J/K
Planck's constant	= 6.626×10^{-34} J-s

SECTION A

- Q1. (a)** An N-type silicon bar of conductivity $\sigma = 1/\Omega\text{-cm}$ has a battery applied across it as shown in the figure below. Assume a hypothetical situation in which the battery is able to sweep some electrons into a region of length 0.03 cm in the middle of the bar, thereby locally increasing the electron density in the region by 1% of the thermal equilibrium density. Make the rough calculation of the order of magnitude of the electric field which will develop there due to this increase in majority carrier density.

Assume, mobility of electron $\mu_n = 1350 \text{ cm}^2/\text{V-s}$,

Permittivity of Si $\epsilon_{\text{Si}} = 10^{-12} \text{ F/cm}$.

12

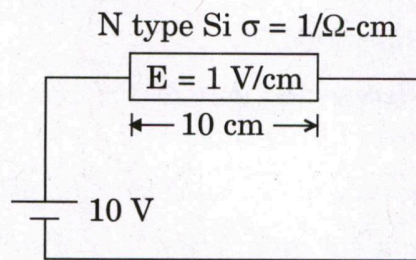

- (b) The work function ϕ_m of platinum is 5 eV and the electron affinity for silicon is $\chi_{\text{Si}} = 4.05 \text{ eV}$. Determine the barrier height ϕ_{Bn} (barrier height for transfer of electron from metal to semiconductor) and ϕ_{BP} (barrier height for transfer) of holes from metal to semiconductor). Also calculate the built-in voltage V_{bi} for metal-semiconductor contact of platinum with N-type silicon having doping concentration $N_D = 2.8 \times 10^{14}/\text{cm}^3$. Assume that effective density of states in the conduction band edge is $N_C = 2.8 \times 10^{19}/\text{cm}^3$, $KT = 0.025 \text{ eV}$ at room temperature, $E_G = 1.1 \text{ eV}$.

12

- (c) Write the mesh current matrix equation for the network of figures shown by inspection, and solve for the currents.

12

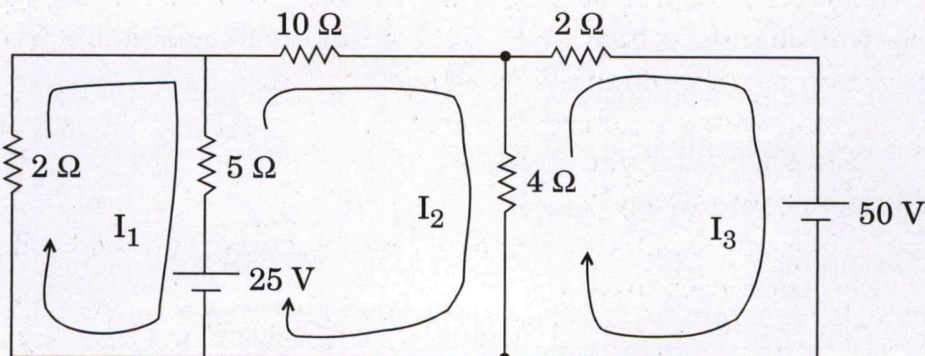

U-ELX-YUGT

- (d) The atomic packing schemes for some hypothetical material for several different crystallographic directions are shown. For each direction the circles represents only those atoms contained within a unit cell, where circles are reduced from their actual diameter/size.

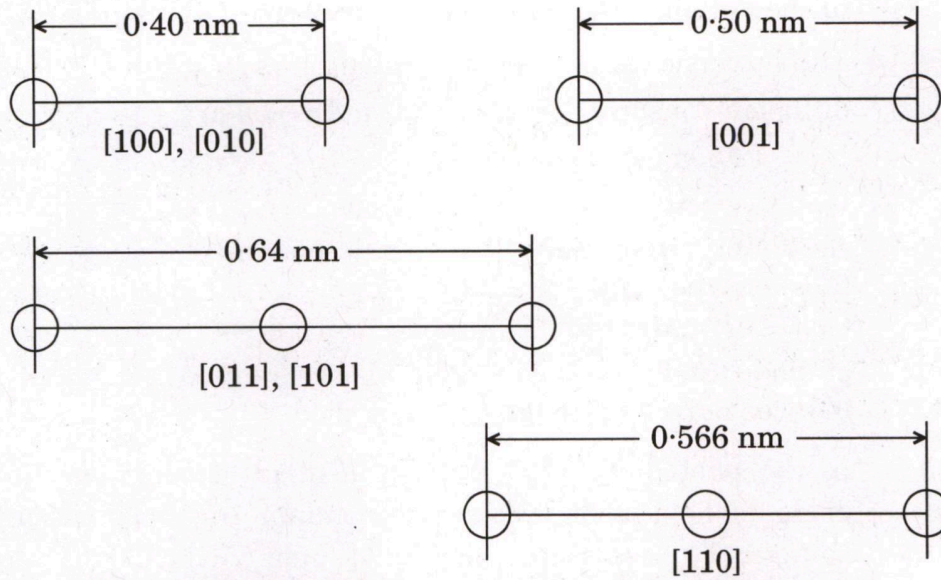

Identify the unit cell and the crystal system it belongs to.

12

- (e) What are the different types of batteries ? How is the right battery selected for an application ?

12

- Q2. (a) Solve for V_0 in the circuit shown in the figure.

20

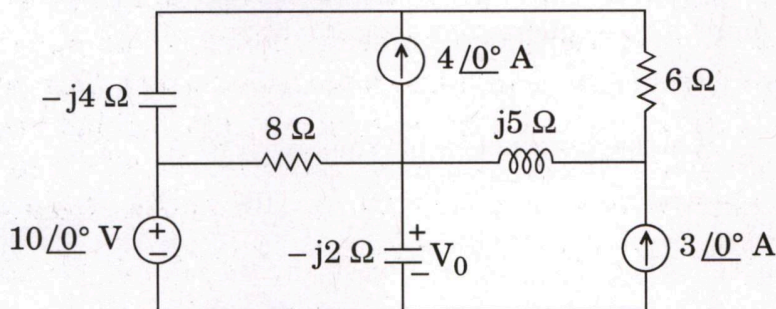

- (b) An MOS capacitor having the gate oxide thickness, $t_{ox} = 0.1 \mu\text{m}$ and substrate boron doping density $N_A = 10^{15}/\text{cm}^3$ is biased in the depletion mode with a gate voltage, V_G . If the surface potential is 0.2 V for this bias condition, determine the following :

$5 \times 4 = 20$

- Peak electric in silicon substrate
- Electric field in the oxide
- The gate voltage V_G
- Thermal equilibrium hole concentration, p_p and the hole concentration, p_s at the silicon surface.

Note that $\epsilon_0 = 8.854 \times 10^{-14} \text{ F/cm}$, $\epsilon_s = 12$ for silicon and $\epsilon_{ox} = 4$ for SiO_2 .

- (c) (i) A silicon P-N junction photodiode has a uniform area of cross-section of $A = 0.04 \text{ cm}^2$.

In the p-region, $N_A = p_p = 1.5 \times 10^{15}/\text{cm}^3$ and

in the N-region, $N_D = n_n = 1.5 \times 10^{13}/\text{cm}^3$.

The intrinsic carrier density in silicon is $n_i = 1.5 \times 10^{10}/\text{cm}^3$. The diffusion constant for electrons and holes are $D_n = 35 \text{ cm}^2/\text{s}$ and $D_p = 12.5 \text{ cm}^2/\text{s}$. Holes lifetime in the N-region is $\tau_p = 100 \mu \text{ sec}$ and electron lifetime in the p-region is $\tau_n = 35 \mu \text{ sec}$. Assuming that light of a suitable mixture of wavelength falls on the diode producing an idealized generation of EHP, $G_L = 10^{16} \text{ pairs/sec/cm}^2$ uniformly at all points within the volume of diode, and the diode is kept short circuited, calculate the light induced current through the photodiode.

15

- (ii) In the photodiode of Q2(c)(i), if instead of short circuiting, the diode is kept open circuited, calculate the open circuit photo voltage, V_{oc} across the diode. Assume $V_T = 0.026 \text{ V}$ at room temperature.

5

- Q3.** (a) (i) Explain, how Burgers vector is invariant of the type of dislocation.

10

- (ii) Out of (100) and (110) crystallographic planes, which plane will have more surface energy for copper single crystal ?

10

Given : Bond energy per bond for copper = 65.4 kJ/mol

Lattice parameter for copper = 3.61 \AA

Avogadro's number = $6.023 \times 10^{23} \text{ g/mol}$

- (b) Use the superposition theorem to find I_o in the circuit shown in the figure.

20

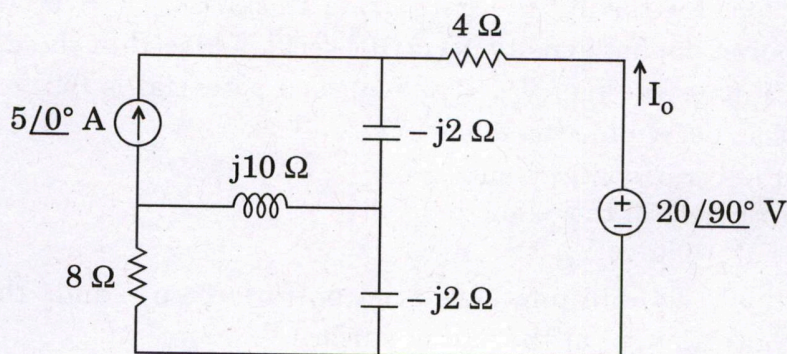

(c) A separately excited DC generator is characterized by the magnetization curve of the figure shown below.

- (i) If the prime mover is driving the generator at 800 rev/min, what is the no-load terminal voltage, V_a ?
- (ii) If a $1\text{-}\Omega$ load is connected to the generator, what is the generated voltage?

20

Generator ratings : 100 V, 100 A, 1000 rev/min

Circuit parameters : $R_a = 0.14\ \Omega$, $V_f = 100\ \text{V}$, $R_f = 100\ \Omega$

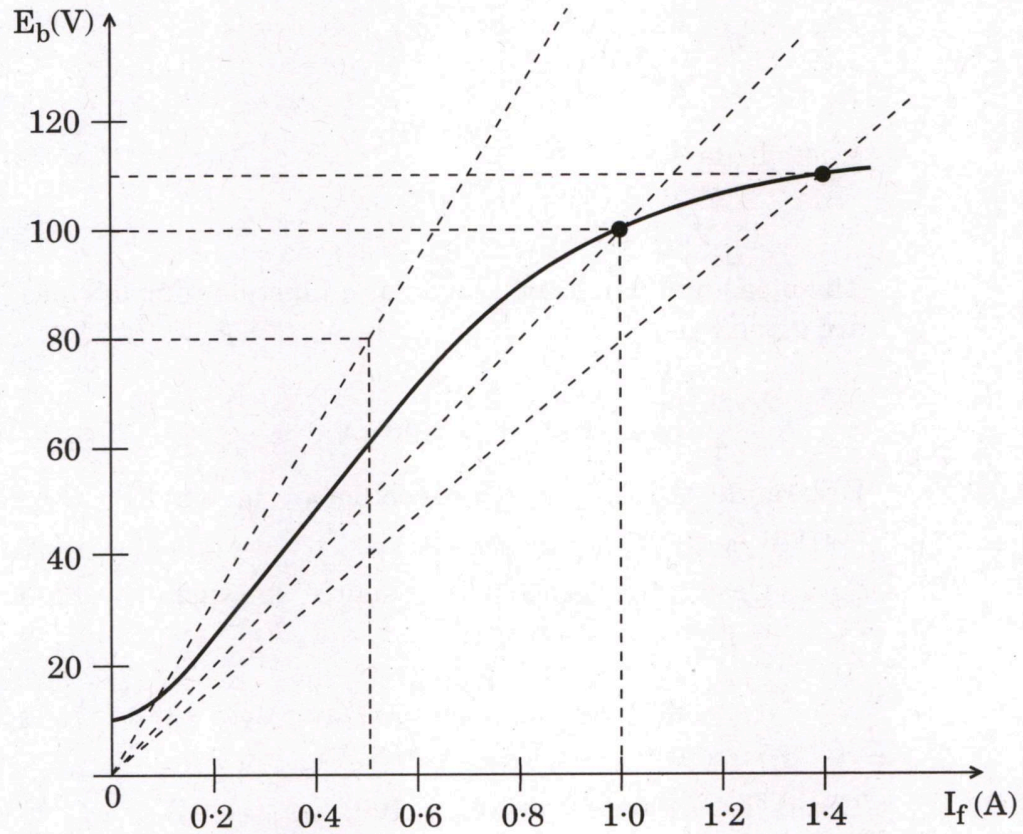

- Q4.** (a) (i) Design a photo detector circuit of the form as shown in the figure below to give an output voltage of $v_o = -200$ mV at an incident power density of $D_P = 500$ nW/cm². The current responsivity of the photodiode is $D_i = 1$ A/W, and the active area is $a = 400$ mm². 10

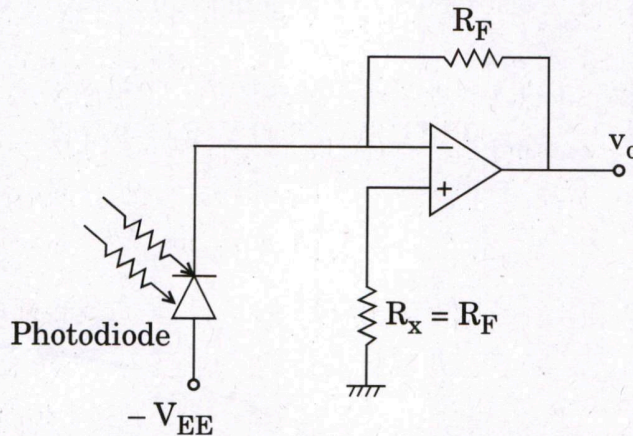

- (ii) The measured values of a diode at a junction temperature of 25°C are given by

$$V_D = \begin{cases} 0.5 \text{ V} & \text{at } I_D = 5 \mu\text{A} \\ 0.6 \text{ V} & \text{at } I_D = 100 \mu\text{A}. \end{cases}$$

Determine the (I) Emission coefficient η , and (II) the leakage current I_s . Assume $V_T = 25.8$ mV. 10

- (b) (i) (I) Design the basic current source shown in the figure below to give an output current, $I_o = 5 \mu\text{A}$.
 (II) For Q4(b)(i)(I) calculate the output resistance R_o , Thevenin's equivalent voltage V_{TH} , and the collector current ratio if $V_{CE_2} = 20$ V. $5 \times 2 = 10$

The BJT parameters are $\beta_F = 100$, $V_{CC} = 30$ V, $V_{BE_1} = V_{BE_2} = 0.7$ V, and the early voltage $V_A = 150$ V.

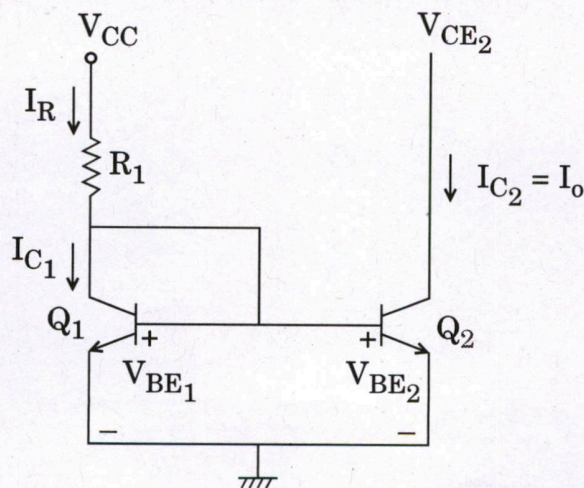

- (ii) Using the phasor approach, determine the current $i(t)$ in a circuit described by the integro-differential equation

$$4i + 8 \int i dt - 3 \frac{di}{dt} = 50 \cos(2t + 75^\circ). \quad 10$$

- (c) (i) Draw a schematic cross-sectional view of a MOSFET transistor. How is the insulating layer fabricated in it and what are the parameters that control the thickness of this layer? 10
- (ii) Classify magnetic materials; and calculate the saturation magnetization and the saturation flux density for nickel. 10

Given : Density of nickel = 8.90 g/cm^3

Atomic weight of nickel = 58.71 g/mol

Net magnetic moment per atom for nickel =

$0.60 \text{ Bohr magneton}$

Bohr magneton = $9.27 \times 10^{-27} \text{ A}\cdot\text{m}^2$

Avogadro's number = $6.023 \times 10^{23} \text{ g/mol}$

SECTION B

- Q5.** (a) The open loop gain of the amplifier shown in the figure below has break frequency at $f_{p1} = 100$ kHz, $f_{p2} = 1$ MHz and $f_{p3} = 10$ MHz. The low frequency gain is $A_o = 200$ A/A and the emitter resistance $R_E = 500 \Omega$. Determine the value of compensating capacitor C_F and resistance R_F to give (i) low frequency closed loop gain of $A_f = 20$ A/A and cancel the pole $f_{p1} = 100$ kHz, and (ii) to add pole of $f_p = 10$ MHz and cancel the pole $f_{p1} = 100$ kHz.

12

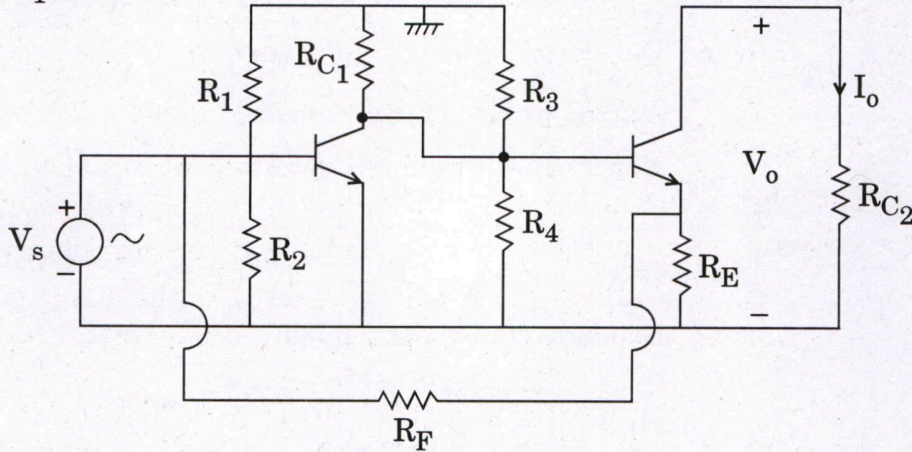

- (b) Determine the Z-parameters for the two-port network shown and check for its symmetry and reciprocity.

12

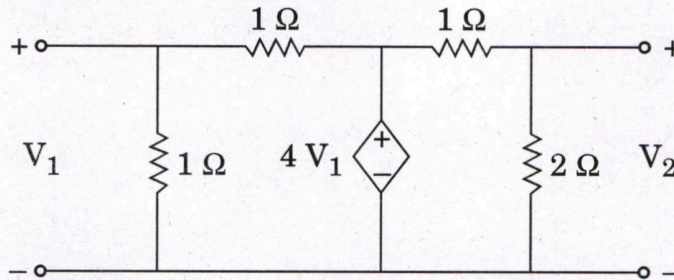

- (c) What is superconductivity? How are the superconducting materials classified? Give the applications of high temperature superconductors, in brief.

12

- (d) How is the temperature compensation achieved in the measurement of strain?

The unstrained resistance of each of the four elements of the unbonded strain gauge is 120Ω . The strain gauge has a gauge factor of 3 and is subjected to a strain of 10^{-4} . If the detector is a high impedance voltmeter, calculate the reading of this voltmeter for a battery voltage of 10 V. Assume the bridge arms A and D are under tension whereas arms B and C are under compression.

12

- (e) In the circuit shown in figure, $Z_1 = 60/\underline{-30^\circ} \Omega$ and $Z_2 = 40/\underline{45^\circ} \Omega$. Calculate the total (i) apparent power, (ii) real power, (iii) reactive power, and (iv) P.f. 12

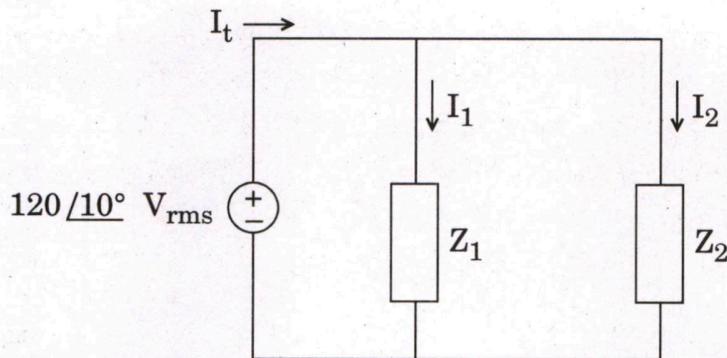

- Q6.** (a) (i) In a CRT, the anode to cathode voltage is 2 kV. The parallel deflector plates are 1.5 cm long and spaced 5 mm apart. The screen is 50 cm from the centre of the deflecting plates. Find the beam speed and deflection sensitivity of the tube. Mass of electron = 9.109×10^{-31} kg, Charge on electron = 1.602×10^{-19} C. 10
- (ii) The coil of a moving iron voltmeter has a resistance of 500 Ω and an inductance of 1.0 H. The series resistor is 2 k Ω . When 250 V dc is applied, the voltmeter reads 250 V. Find the reading when an ac voltage of 250 V, 50 Hz is applied. What is the per cent error? What capacitance must be connected in parallel with the series resistor to remove this error? 10
- (b) (i) An ac bridge has the following constants :
 arm AB, $R = 1$ k Ω in parallel with $C = 0.159 \mu F$;
 arm BC, $R = 1$ k Ω ; arm CD, $R = 500 \Omega$; arm DA, $C = 0.636 \mu F$ in series with an unknown resistor. Find the frequency for which the bridge is in balance and determine the value of resistance in arm DA to produce this balance. 10
- (ii) A dynamometer type wattmeter connected normally to read power in a single phase circuit indicates the value P_1 . A second reading P_2 is obtained when a capacitor of reactance equal to the pressure coil resistance is connected in series with pressure coil. Show that the phase angle of the load can be obtained from the expression : $\tan \phi = 1 - \frac{2P_2}{P_1}$. 10

- (c) Design a counter with the irregular binary count sequence shown in the state diagram of the following figure. Use J-K flip-flops. 20

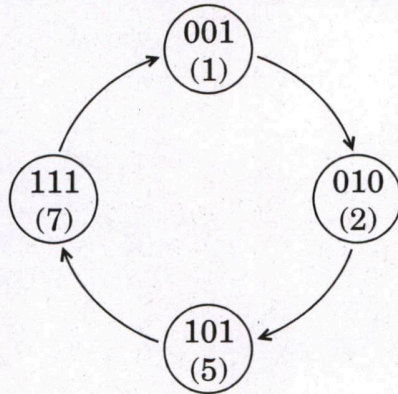

- Q7. (a) (i) For the circuit shown, obtain the state equations for $R_1 = R_2 = R$. 12

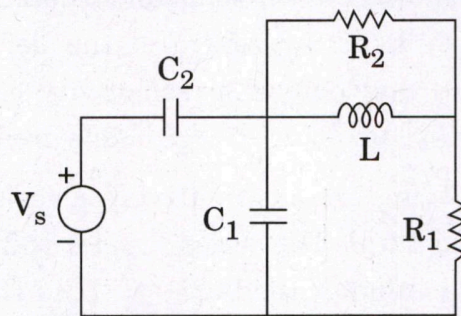

- (ii) A two-element series circuit is connected across an ac source given by $e(t) = 200\sqrt{2} \sin(314t + 20^\circ)$. The current in the circuit is found to be $i(t) = 10\sqrt{2} \cos(314t - 25^\circ)$. Determine the parameters of the circuit. 8
- (b) (i) A chromel-constantan thermocouple has its cold junction at 0°C . The characteristics of the thermocouple is :

Temp. $^\circ\text{C}$	0	10	20	30	40	50
emf mV	0	0.593	1.191	1.8	2.415	3.02

Find the temperature of the hot junction if the thermoelectric emf is 2.95 mV. 10

- (ii) A thermometer, initially at 70°C , is suddenly dipped in a liquid at 300°C . After 3 seconds, the thermometer indicates 200°C . After what time is the thermometer expected to give a reliable reading, say well within 1% of the actual value? 10

- (c) Find the load voltage as a function of time for the circuit shown in the figure. Assume no energy is stored in the capacitor and inductor before the switch closes. Circuit parameters : $R = 10 \Omega$, $C = 10 \mu\text{F}$, $L = 5 \text{ mH}$. 20

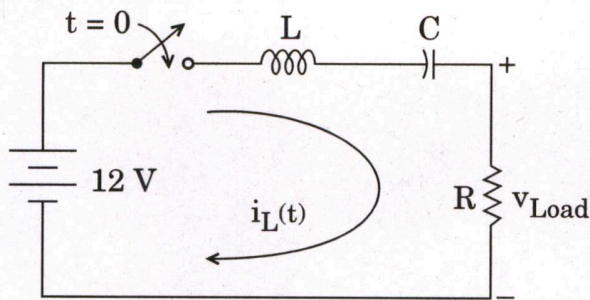

- Q8. (a) (i) Design a sawtooth waveform generator shown in the figure below, so that $f_o = 4 \text{ kHz}$, threshold voltage $V_{\text{TH}} = 5 \text{ V}$ and the circuit has a duty cycle of 0.25. Assume $V_{\text{sat}} = | -V_{\text{sat}} | = 14 \text{ V}$, and $R_1 = 10 \text{ k}\Omega$ and $C = 0.01 \mu\text{F}$. 10

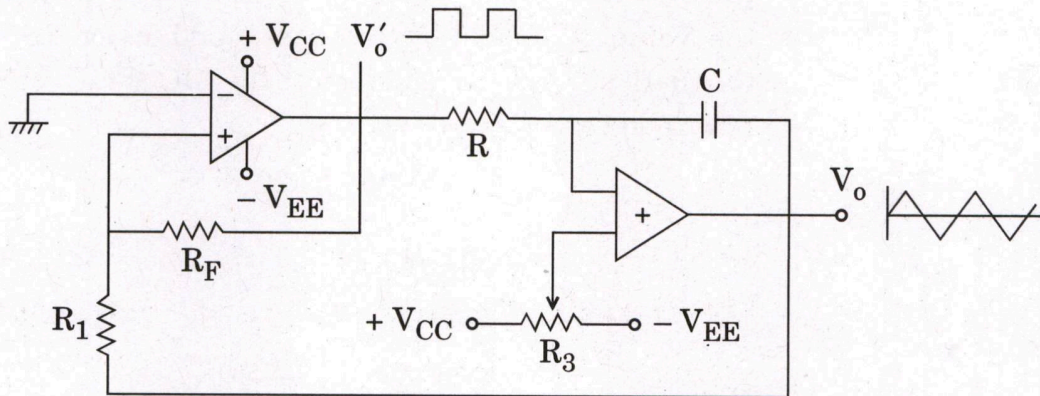

- (ii) Design a square wave generator as shown in the figure below, so that duty cycle is 50% and $f_o = 2.5 \text{ kHz}$. Assume $V_{\text{CC}} = 12 \text{ V}$ and $C = 0.1 \mu\text{F}$. 10

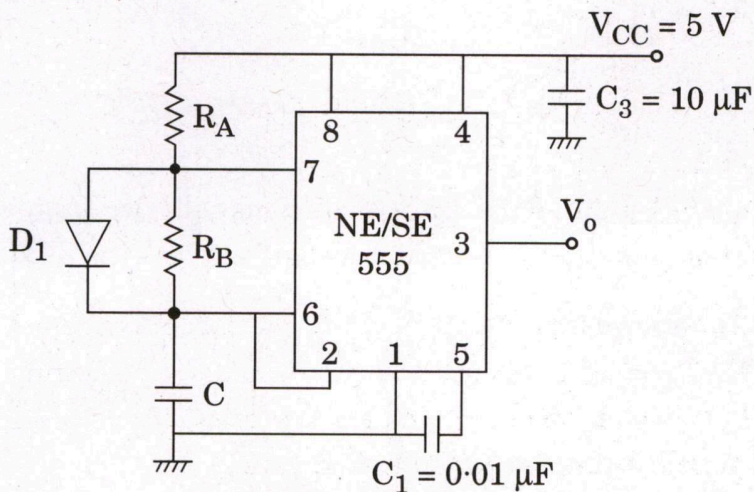

- (b) (i) For a second order low pass filter as shown in the figure below, to give a high cutoff frequency of $f_H = f_o = 1$ kHz, a pass band gain $K = 4$, $Q = 0.707$ and $C = 0.01 \mu\text{F}$. Calculate resistances R , R_F and R_5 .

10

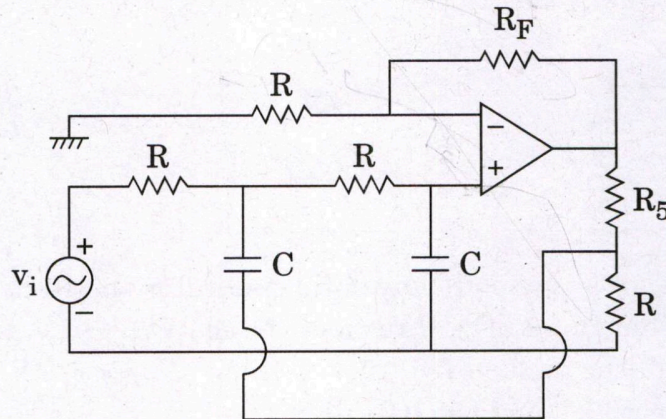

- (ii) An LC tuned MOS oscillator is shown in the figure below. Find the value of oscillation frequency and n for $L = 112.6 \mu\text{H}$ and $C = 0.01 \mu\text{F}$. The parameters of the MOSFET are $g_m = 5 \text{ mA/V}$, $r_d = 25 \text{ k}\Omega$ and $R_G = 10 \text{ k}\Omega$.

10

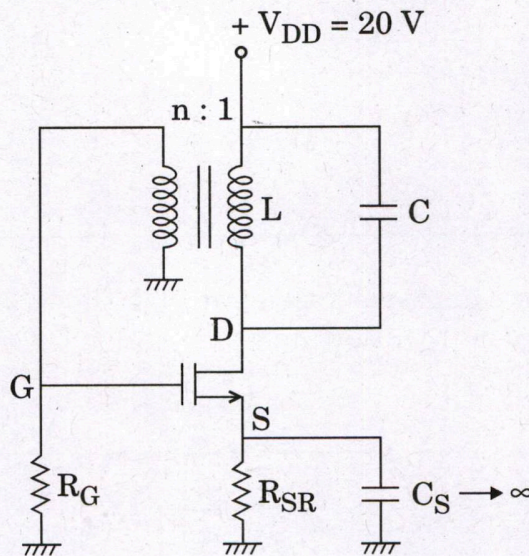

- (c) Draw a 16×8 -bit ROM array, showing all the inputs and outputs. List the types of read-only memories and explain the differences.

20