

ELECTRICAL ENGINEERING**Paper - II****Time Allowed : Three Hours****Maximum Marks : 300****Question Paper Specific Instructions**

Please read each of the following instructions carefully before attempting questions :

*There are **EIGHT** questions divided in **TWO** sections.*

*Candidate has to attempt **FIVE** questions in all.*

*Questions No. 1 and 5 are **compulsory** and out of the remaining, **THREE** are to be attempted choosing at least **ONE** question from each Section.*

The number of marks carried by a question / part is indicated against it.

Wherever any assumptions are made for answering a question, they must be clearly indicated.

Diagrams / Figures, wherever required, shall be drawn in the space provided for answering the question itself.

Unless otherwise mentioned, symbols and notations have their usual standard meanings.

Attempts of questions shall be counted in sequential order. Unless struck off, attempt of a question shall be counted even if attempted partly.

Any page or portion of the page left blank in the Question-cum-Answer Booklet must be clearly struck off.

*Answers must be written in **ENGLISH** only.*

SECTION A

- Q1. (a) For the circuit shown in the figure below, derive the expression for output voltage and sketch the nature of the output when $V_2 = 10\text{ V}$ and $V_1 = 5\text{ V}$. 12

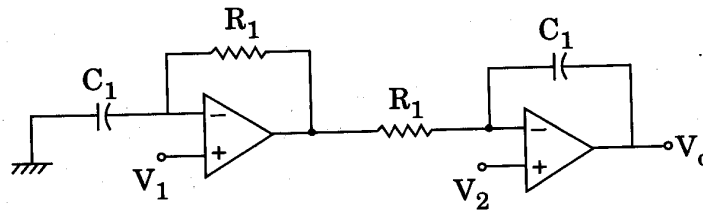

- (b) A continuous LTIV system S with frequency response $H(j\Omega)$ is constructed by cascading two continuous-time LTIV systems with frequency response $H_1(j\Omega)$ and $H_2(j\Omega)$, respectively. Figures a and b show the straight-line approximations of Bode magnitude plots of $H_1(j\Omega)$ and $H(j\Omega)$, respectively. Find $H_2(j\Omega)$. 12

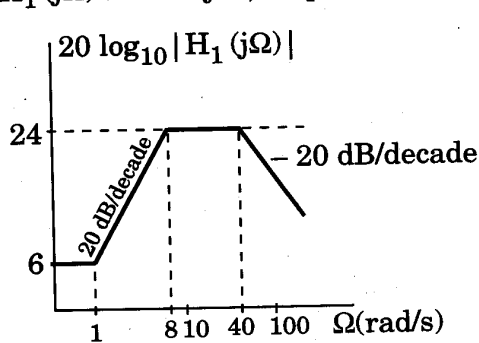

(a)

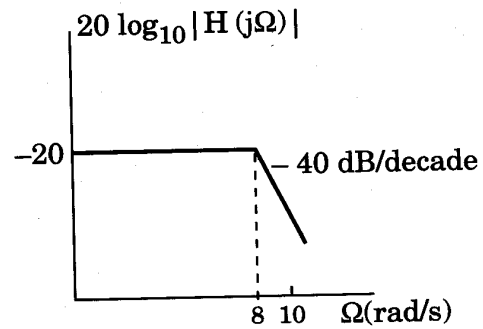

(b)

- (c) Consider a three-phase induction motor with the following parameters :

Number of poles	: 4
Supply frequency	: 50 Hz
Full load speed	: 1470 rpm
Rotor resistance	: $0.12\ \Omega$
Standstill reactance	: $1.12\ \Omega$

Find the

- (i) Slip for maximum torque 4
- (ii) Ratio of maximum torque to full load torque. 8

- (d) (i) What is Smart Grid ? 4
- (ii) Compared to Supervisory Control And Data Acquisition (SCADA) system, what are the advantages of Phasor Measurement Unit (PMU) ? 4
- (iii) Explain operation of PMU with a neat diagram. 4

- (e) A PV panel is connected with a single phase fully controlled converter as shown in the circuit below. The panel is supplying a current of 5 A and generated power is 1000 W. The series inductance in the circuit is large to make the current flat and continuous. Find (i) the triggering angle of the thyristor bridge, (ii) output voltage at rectifier terminal, and (iii) input power factor. 12

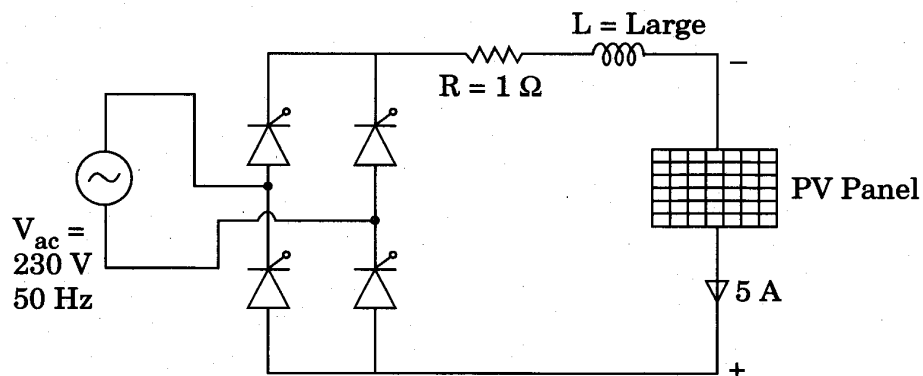

- Q2.** (a) The DC – DC converter given below is operating at 30 kHz and drawing an input current of 25 A at 48 V DC.
- (i) For a load current of 10 A, find
- the duty ratio of the switch,
 - output voltage,
 - peak inductor current,
 - output voltage ripple, and
 - the load current where the inductor current just becomes discontinuous.

- (ii) Also find the critical value of L to keep the inductor current just continuous when the input voltage changes to 60 V with output remaining same.

(Assume lossless operation of converter components)

20

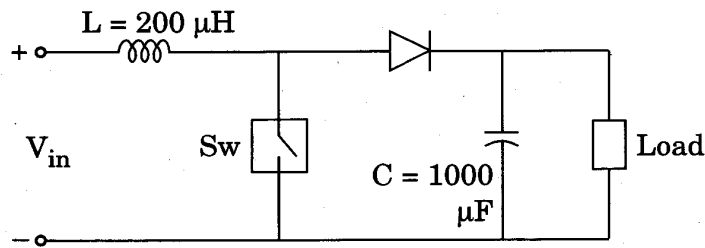

- (b) A signal $m(t) = 2 \cos(20\pi t) - \cos(40\pi t)$, where the unit of time is millisecond, is amplitude modulated using the carrier frequency (f_c) of 600 kHz. The AM signal is given by

$$s(t) = 5 \cos 2\pi f_c t + m(t) \cos 2\pi f_c t$$

- (i) Sketch the magnitude spectrum of $s(t)$. What is its bandwidth? 5
- (ii) What is the modulation index? 5
- (iii) The AM signal is passed through a high-pass filter with cut-off frequency 595 kHz (i.e., the filter passes all frequencies above 595 kHz, and cuts off all frequencies below 595 kHz). Find an explicit time-domain expression for the quadrature component of the filter output with respect to a 600 kHz frequency reference. 10
- (c) A 400 V DC shunt motor has armature and field resistances of 0.2 Ω and 200 Ω respectively. It draws a current of 6 A on no-load and 70 A on full-load. If its no-load and full-load speeds are the same, determine the field weakening due to load current as percentage of no-load flux. 20

- Q3.** (a) A salient pole star connected alternator is connected to infinite bus operating at 1.0 p.u. voltage. The alternator has $X_d = 0.75$ p.u. and $X_q = 0.5$ p.u. on per phase basis. It is delivering 1.0 p.u. power to the infinite bus at 0.8 p.f. lag. Calculate (i) the load angle and excitation voltage under this condition, (ii) the maximum power that can be delivered by the alternator with same excitation and the corresponding load angle, (iii) the armature current and p.f. under maximum power condition, and (iv) the theoretical value of maximum power that the alternator can deliver when its field circuit is suddenly disconnected due to fault. 20

- (b) A closed loop system with unity feedback and having the forward loop transfer function as

$$G(s) = \frac{14.4}{s(1 + 0.1s)}$$

Modify the design using cascaded compensation to satisfy the optimum performance criterion, so that the transient response to unit step input reaches its final steady state value in minimum time without having any overshoot. 20

- (c) Two 11 kV, 30 MVA, three-phase synchronous generators operate in parallel supplying a sub-station through a feeder having an impedance of $(0.6 + j0.8)$ ohms to positive and negative sequence currents and $(1.0 + j2.6)$ ohms to zero sequence currents. Each generator has $X_1 = 0.8$ ohms, $X_2 = 0.5$ ohms and $X_0 = 0.2$ ohms and has its neutral grounded through a reactance of 0.2 ohms. Evaluate the fault currents in each line and the potential above earth attained by the generator neutrals, consequent to simultaneous occurrence of earth fault on the Y and B phases at the sub-station. 20

- Q4.** (a) A signal $g(t)$ band limited to B Hz is sampled by a periodic pulse train $p_T(t)$ made up of a rectangular pulse of width $\frac{1}{8B}$ sec (centered at origin) repeating at the Nyquist rate (2 B pulses per sec). Show that the sampled signal $g_s(t)$ is given by

$$g_s(t) = \frac{1}{4}g(t) + \sum_{n=1}^{\infty} \frac{2}{n\pi} \sin\left(\frac{n\pi}{4}\right) g(t) \cos(4n\pi Bt)$$

How will you recover $g(t)$ from the signal $g_s(t)$? 15+5

- (b) A 3-phase half-controlled rectifier with free-wheeling diode is supplying a separately excited DC motor for speed control purpose. The AC input to the converter is 415 V, 3-phase, 50 Hz. The motor parameters are :

$$V = 220 \text{ V DC}, P = 10.5 \text{ kW}$$

Rated speed = 1100 rpm, Armature resistance $r_a = 0.4 \Omega$.

The field current is kept constant at rated value. The motor is operated at rated speed delivering half rated torque.

- (i) Find motor terminal voltage and triggering angle of thyristor bridge.

(ii) Find the speed of the motor if one of the input phases to the converter is out due to fault and the triggering angle is kept as before with same load torque.

(iii) Also find the new triggering angle if the motor speed is to be maintained at rated value with same load torque.

(Neglect losses in the machine) 20

(c) The figure below shows single line diagram of a power system with generators at bus-1 and bus-3. The voltage at bus-1 is $1.05 \angle 0^\circ$ p.u. and at bus-3, $|V| = 1.04$ p.u. Line impedances are in p.u. and line charging susceptances are neglected. Obtain state vector using Fast Decoupled Load Flow (FDLF) for one iteration. 20

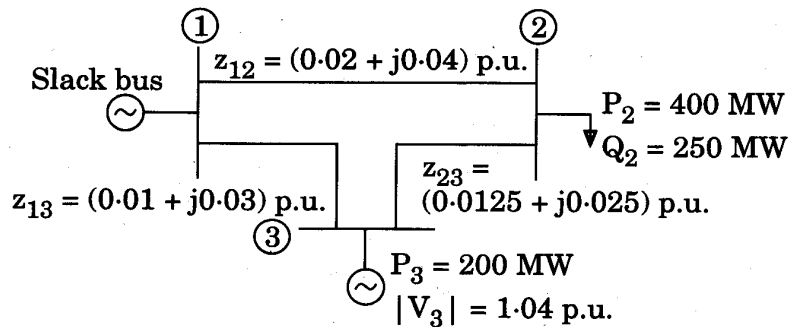

SECTION B

- Q5. (a)** A thyristor is having the I-V characteristic as given in the figure below. It is used in a half wave rectifier circuit with resistive load operating at $\alpha = 30^\circ$ and carrying a peak load current of 100 A. Determine the average conduction loss in the thyristor. 12

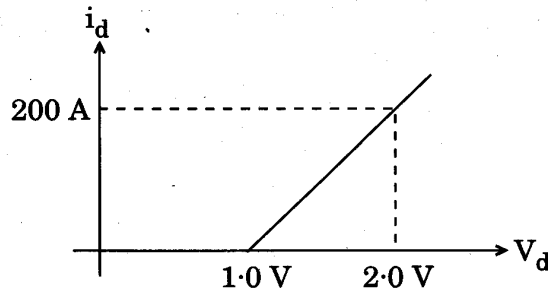

- (b) A three-phase equilateral transmission line has a total corona loss of 55 kW at 110 kV and 100 kW at 114 kV. What is the disruptive critical voltage between lines? What is the corona loss at 120 kV? 12

- (c) A Gaussian pulse is specified by

$$g(t) = Ae^{-\alpha^2 t^2},$$

where α is an arbitrary attenuation coefficient and A is constant. Show that the Fourier transform of $g(t)$ is also Gaussian. 12

- (d) What are the advantages and limitations of Lead and Lag networks in a practical control system? 12

- (e) For a Scott connected transformer, prove that the number of turns on primary of the teaser transformer is $\frac{\sqrt{3}}{2}$ times the number of turns in primary of main transformer. 12

- Q6.** (a) A 15 kW, 400 V, 3-phase, star connected synchronous motor has synchronous impedance of $0.4 + j4 \Omega$. Find the motor excitation voltage for full load output at 0.866 leading power factor. Take the armature efficiency of 95%.

20

- (b) A synchronous machine is connected to an infinite bus through a transformer and a double circuit line shown in the figure. The infinite bus voltage is $V = 1.0 \angle 0^\circ$ p.u. The direct axis transient reactance of the machine is 0.20 p.u., the transformer reactance is 0.10 p.u. and the reactance of each of the transmission lines is 0.4 p.u., all to a base of the rating of the synchronous machine. Initially the machine is delivering 0.8 p.u. power with a terminal voltage of 1.05 p.u. The inertia constant $H = 5$ MJ/MVA. All resistances are neglected. Determine the equation of motion of the machine rotor.

20

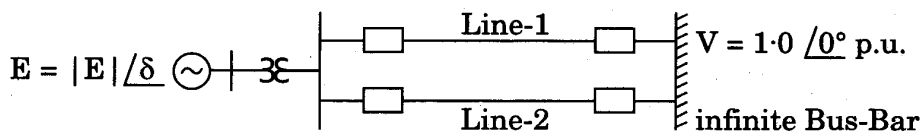

- (c) The open loop transfer function of unity feedback control system is given by

$$G(s) = \frac{K}{s(s+a)(s+b)} \quad 0 < a \leq b$$

- (i) Find the range of the gain constant $K (> 0)$ for stability using Routh-Hurwitz criterion.
- (ii) What type of control do you use if the system is required to have zero steady-state error for ramp input? Let 'A' be the parameter that can be varied in the introduced control. Find the range of 'K' for stability in terms of parameters a , b and A using Routh-Hurwitz criterion.

20

- Q7. (a) A system consists of two plants connected by a transmission line and a load is at power plant-2 as shown in the figure. Data for the loss equation consists of the information that 200 MW transmitted from plant-1 to the load results in transmission loss of 20 MW. Find the optimum generation schedule considering transmission losses to supply a load of 204.41 MW. Also evaluate the amount of financial loss that may be incurred if at the time of scheduling transmission losses are not coordinated. The incremental fuel cost characteristics of plant-1 and plant-2 are given by

20

$$\frac{df_1}{dP_1} = 0.025 P_1 + 14 \quad \text{₹/MW-hr}$$

$$\frac{df_2}{dP_2} = 0.05 P_2 + 16 \quad \text{₹/MW-hr}$$

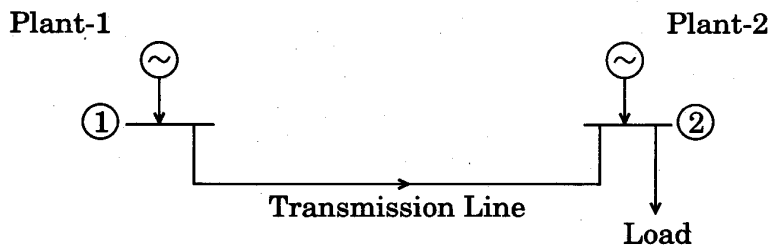

- (b) A continuous-time integrator has a system function $H_a(s) = \frac{1}{s}$.
- (i) Design a discrete-time integrator using bilinear transformation and find the difference equation relating the input $x[n]$ to the output $y[n]$ of the discrete-time system. 10
- (ii) Find the frequency response of the discrete-time integrator found in part (i) and determine whether or not this system is a good approximation of the continuous time system. 10

$$\left(\text{For } \theta \ll 1, \sin \theta \approx \theta \text{ and } \cos \theta \approx 1 - \frac{\theta^2}{2}\right)$$

- (c) For a 3-phase, 50 Hz, 415 V, 4-pole induction motor, the standstill resistance and reactance are 3.0Ω and 5.0Ω at 50 Hz respectively. The machine has magnetising inductance of 350 mH and stator resistance of 1.2Ω . The machine is supplied from a 3-phase voltage source inverter with quasi square wave output voltage waveform per phase as shown in the figure below. The DC bus voltage is 500 V.

If the machine is operating at 4% slip, find (i) the fundamental input current, (ii) harmonic copper losses in the machine up to 13 harmonics, and (iii) input power factor.

Assume negligible core losses, equal distribution of stator and rotor leakage reactances and linear magnetic circuit.

20

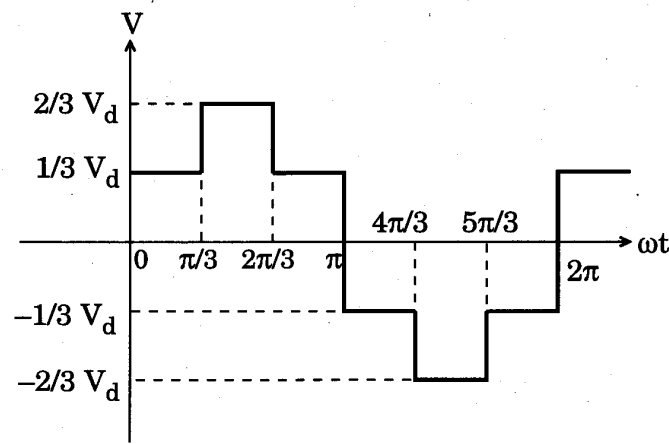

- Q8. (a) A 50 Hz, 3-phase induction motor has a slip of 0.2 for maximum torque, when operated on rated frequency and rated voltage. If the motor is run on 60 Hz supply with application of rated voltage, find the ratio of

- | | |
|-----------------------|---|
| (i) Starting currents | 7 |
| (ii) Starting torques | 7 |
| (iii) Maximum torques | 6 |

with respective values at 50 Hz.

Neglect the stator impedance.

- (b) The current of an induction motor is sensed through a suitable arrangement and converted to equivalent voltage. The current contains fundamental and higher order 5th and 7th harmonics. In order to separate the fundamental, the equivalent voltage waveform is passed through the following circuit as given in figure. Find the (i) cut-off frequencies of each section, (ii) overall gain attenuation in dB for fundamental, 5th and 7th harmonics, and (iii) overall phase shift of the measured fundamental current.

20

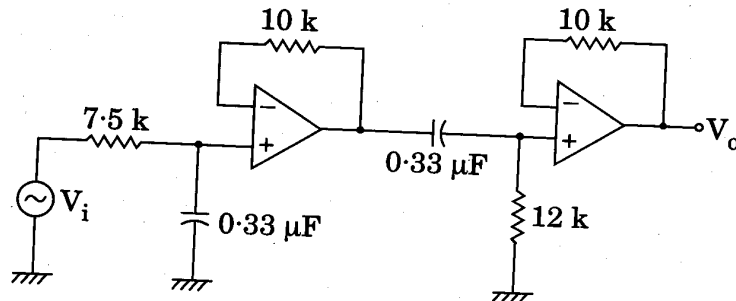

- (c) Given the following facts about a real signal $x(t)$ with Laplace transform $X(s)$:

- A : $X(s)$ has exactly two poles
- B : $X(s)$ has no zeros in the finite s -plane
- C : $X(s)$ has a pole at $s = -1 + j$
- D : $e^{2t} x(t)$ is not absolutely integrable
- E : $X(0) = 8$

Determine $X(s)$ and specify its region of convergence.

10+10

