

ELECTRICAL ENGINEERING

Paper I

Time Allowed : Three Hours

Maximum Marks : 300

QUESTION PAPER SPECIFIC INSTRUCTIONS

Please read each of the following instructions carefully before attempting questions.

There are **EIGHT** questions divided in **TWO** Sections.

Candidate has to attempt **FIVE** questions in all.

Question Nos. **1** and **5** are **compulsory** and out of the remaining, any **THREE** are to be attempted choosing at least **ONE** question from each Section.

The number of marks carried by a question / part is indicated against it.

Wherever any assumptions are made for answering a question, they must be clearly indicated.

Diagrams/figures, wherever required, shall be drawn in the space provided for answering the question itself.

Unless otherwise mentioned, symbols and notations have their usual standard meanings.

Attempts of questions shall be counted in sequential order. Unless struck off, attempt of a question shall be counted even if attempted partly.

Any page or portion of the page left blank in the Question-cum-Answer Booklet must be clearly struck off.

Answers must be written in **ENGLISH** only.

SECTION 'A'

- 1.(a) Determine the eigen vectors of the matrix

$$\begin{bmatrix} -2 & 2 & -3 \\ 2 & 1 & -6 \\ -1 & -2 & 0 \end{bmatrix}$$

Show that those eigen vectors are linearly independent.

12

- 1.(b) Discuss superconductivity, superconducting materials and their applications.

12

- 1.(c) Find the force with which the plates of a parallel-plate capacitor attract each other. Also determine the pressure on the surface of the plate due to the field.

12

- 1.(d)

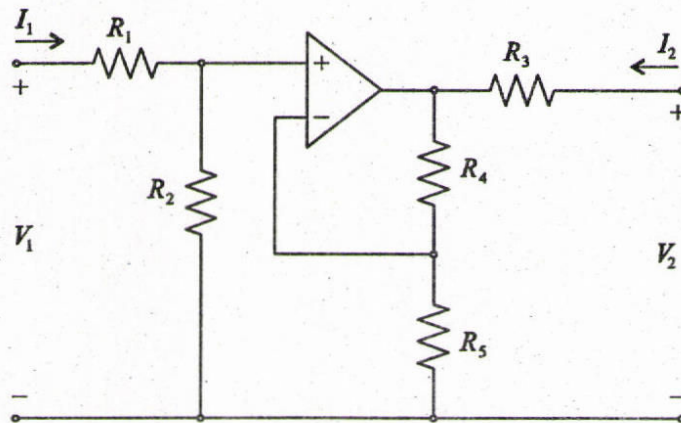

Find the z parameters of the network shown in the figure. Is the network reciprocal? If so why? Assume the operational amplifier is ideal.

12

- 1.(e) Volume charge density is the same as the divergence of the electric flux density. Using Gauss's law, derive equations to prove it.

12

- 2.(a) Find the difference between the values of $\int_C \phi d\vec{r}$, $\phi(x, y) = x^3y + 2y$ from $(1, 1, 0)$ to $(2, 4, 0)$ along the curve $y = x^2, z = 0$ and along the straight line joining $(1, 1, 0)$ and $(2, 4, 0)$. Hence evaluate $\int_C (\nabla \cdot \vec{f}) d\vec{r}$, where $\vec{f} = \frac{1}{4}x^4y\hat{i} + y^2\hat{j} + xy\hat{k}$ along the curve which is a parabola $y = x^2, z = 0$ from $(1, 1, 0)$ to $(2, 4, 0)$.

20

- 2.(b) (i) State Hall effect and discuss the applications of Hall effect.

12

- (ii) A flat silver strip of width 1.5 cm and thickness 1.5 mm carries a current of 150 amperes. A magnetic field of 2.0 Tesla is applied perpendicular to the flat face of the strip. The emf developed across the width of the strip is measured to be $17.9 \mu V$ (Hall effect). Estimate the number density of free electrons in the metal.

8

2.(c)

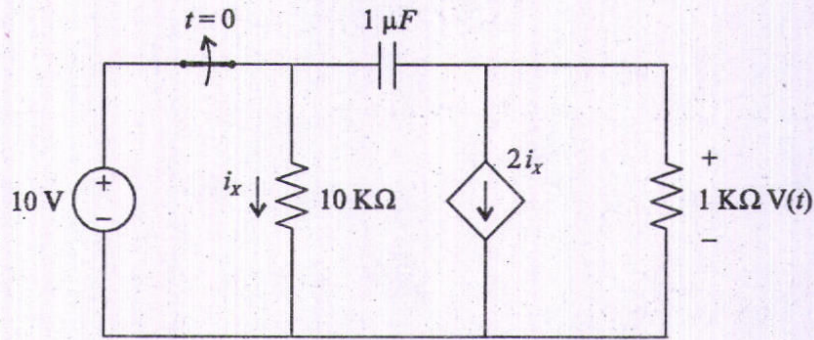

For the circuit shown in figure,

- (i) Find the expression of $V(t)$, the voltage across $1k\Omega$ resistor when the switch is opened at time $t = 0$.
- (ii) Sketch $V(t)$ with respect to time (t) and mark the time constant τ . 20

- 3.(a) A string of flexible wire stretched on a sitar has its ends fixed at $x = 0$ and $x = 20$. Initially at $t = 0$, the string is at rest and takes the shape as defined by $h(x) = \mu(20x - x^2)$, μ being a constant, and then it is released to vibrate. Formulate this boundary value problem and solve that to find the displacement at any point x at an instant t . The solution, to be obtained, should involve definite constants not the arbitrary ones. 20

3.(b)

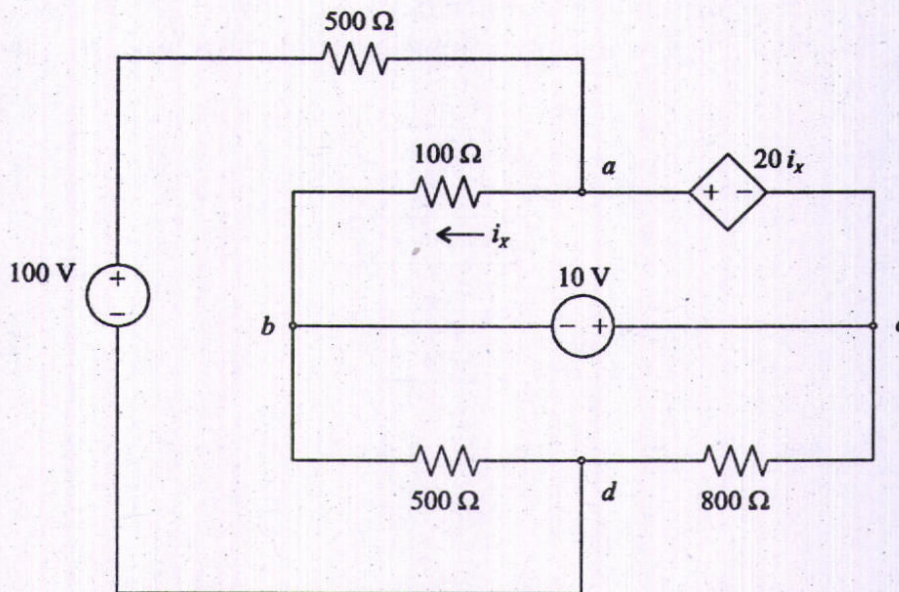

For the circuit shown in the figure,

- (i) Find the node voltages.
- (ii) Power absorbed by the 800Ω resistor. 20

- 3.(c) List properties of ceramic materials and write their applications in technology. 20

- 4.(a) (i) An electrostatic field in xy -plane is given by $\phi(x, y) = 3x^2y - y^3$.
Find the stream function ψ such that the complex potential $\omega = \phi + i\psi$ is an analytic function. 8
- (ii) Find three Laurent's series expansions of the function $f(z) = \frac{1}{3z - z^2 - 2}$ and specify the regions in which those expansions are valid. 12
- 4.(b) What are magnetic materials? Give classification of magnetic materials and name some materials in each class. 20
- 4.(c) (i) Show that in a source-free region ($J = 0, \rho_v = 0$), Maxwell's equations can be reduced to two. Identify the two all-embracing equations. 10
- (ii) Determine the total charge for the following: 10
- (A) on a line $0 \leq x \leq 5\text{m}$ if $\rho_L = 12x^2$ milli C/m
- (B) on a cylinder $\rho = 3, 0 \leq z \leq 4\text{m}$ if $\rho_s = \rho z^2$ nC/m²

SECTION 'B'

- 5.(a) (i) Determine the possible base of the number in the operation mentioned below :
 $23 + 44 + 14 + 32 = 223$ 4
- (ii) Find the minimal sum of products (SOP) expression of the following boolean function $f(a, b, c, d)$
 $f(a, b, c, d) = abc + abd + a'bc' + cd + bd'$
where a', b', c' and d' are complements of variables a, b, c and d respectively. 4

(iii)

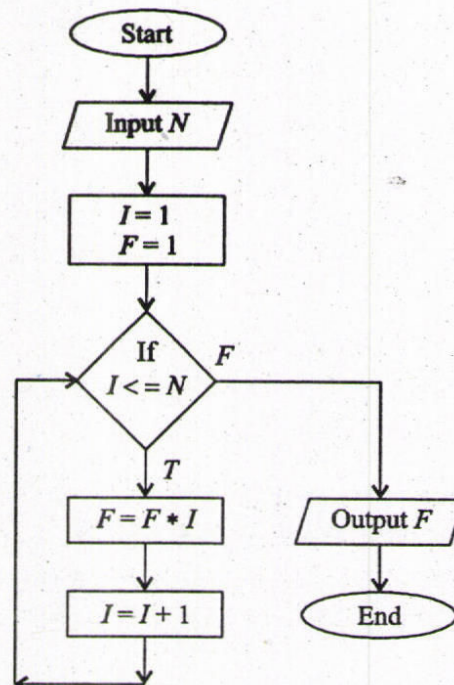

What computation is performed by the given flowchart? Perform dry run and write down problem statement. 4

5.(b) A $4\frac{1}{2}$ digit and a $3\frac{1}{2}$ digit voltmeter on 10V range are used for voltage measurements.

(i) Find the resolution of each meter.

(ii) How would the reading 0.7582 be displayed on these two meters? 12

5.(c) A 1000/5A, 50Hz current transformer at its rated load of 50VA has an iron loss of 0.5W and a magnetizing current of 8A. Calculate the ratio error and phase angle when rated output is supplied to a meter whose resistance is 0.4Ω and inductance is 0.7mH. 12

5.(d)

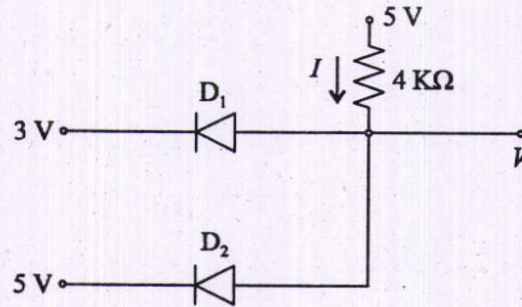

(i) For the circuit shown in the above figure using ideal diodes, find the values of the voltage V and current I indicated in the figure. 6

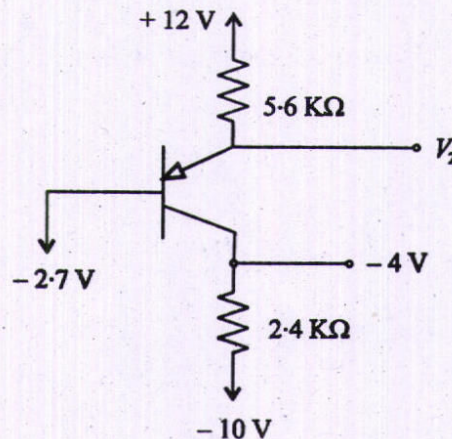

(ii) For the circuits in the above figure assume that the transistor have very large β . Some measurements have been made on these circuits, the results are indicated in the figure. Find the values of the voltage V_2 . 6

5.(e) (i) Bipolar junction transistors (BJTs) are considered "normally off" devices, because their natural state with no signal applied to the base is no conduction between emitter and collector, like an open switch. Are junction field effect transistors (JFETs) considered the same? Why or why not? Justify your answer. 6

(ii) How an n -channel enhancement mode MOSFET can be used to switch a motor on and off? Justify your answer. 6

- 6.(a) (i) What are the different types of registers generally contained in the central processing unit? Explain functions of each Register used in computer systems. 10
- (ii) List the steps involved in Interrupt drivers I/O with a suitable pseudo code/flowchart from the view of an I/O module. 10

6.(b) In a single-phase power measurement test by three-voltmeter method, the following readings were obtained. Across AC mains is 200V; across the non-inductive resistance of 10Ω is 110V; across the load consisting of resistance(R) and inductance(L) is 120V.

- (i) Calculate the power supplied to the load. 20
- (ii) Calculate the inductive reactance(X_L) and resistance(R) of the load. 20

6.(c)

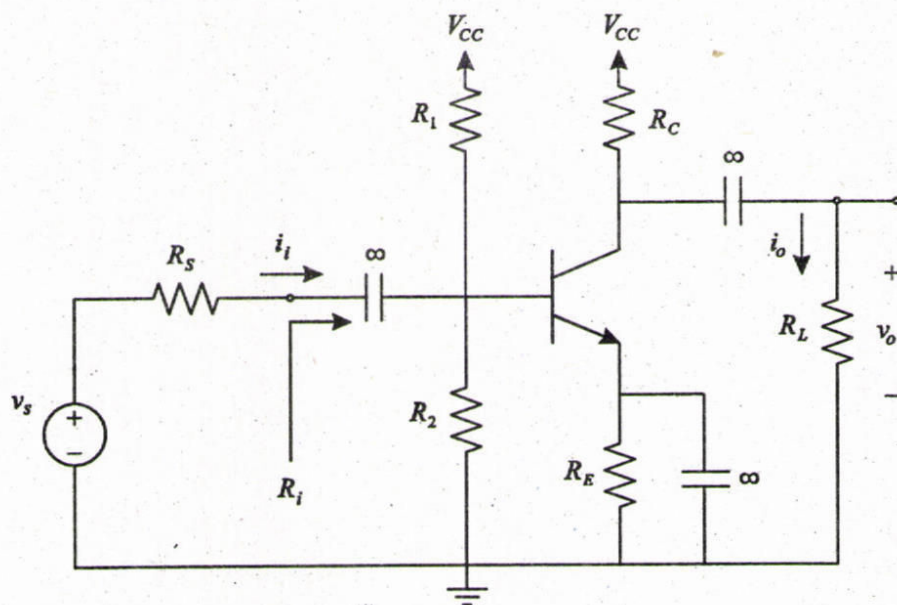

For the common-emitter amplifier shown in the figure, let $V_{cc} = 9V$, $R_1 = 27K\Omega$, $R_2 = 15K\Omega$, $R_E = 1.2K\Omega$ and $R_C = 2.2K\Omega$. The transistor has $\beta = 100$ and $V_A = 100V$ ($V_A =$ Early Voltage). Calculate the dc bias current I_E . If the amplifier operates between a source for which $R_s = 10K\Omega$ and a load of $2K\Omega$ (R_L), replace the transistor with its hybrid- π model, and find the values of R_i and voltage gain v_o/v_s . Assume $V_{BE} = 0.7V$, V_T (thermal voltage) = 25mV. 20

- 7.(a) (i) Write a program in any programming language to find highest common factor (HCF) of two positive integer numbers. 10
- (ii) In virtual memory based system, suppose we have an average of one page fault after every 10,000,000 instructions. A normal instruction takes 4ns (4 nano seconds), and a page fault causes the instructions to take an additional 10 milli seconds. What is the average instruction time, taking page faults into account? 10

- 7.(b) Calculate the reading of
- Moving coil voltmeter
 - Moving iron voltmeter

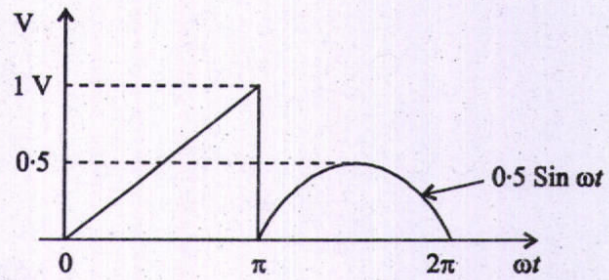

when these voltmeters are measuring the voltage of the waveform shown in the figure. 20

7.(c)

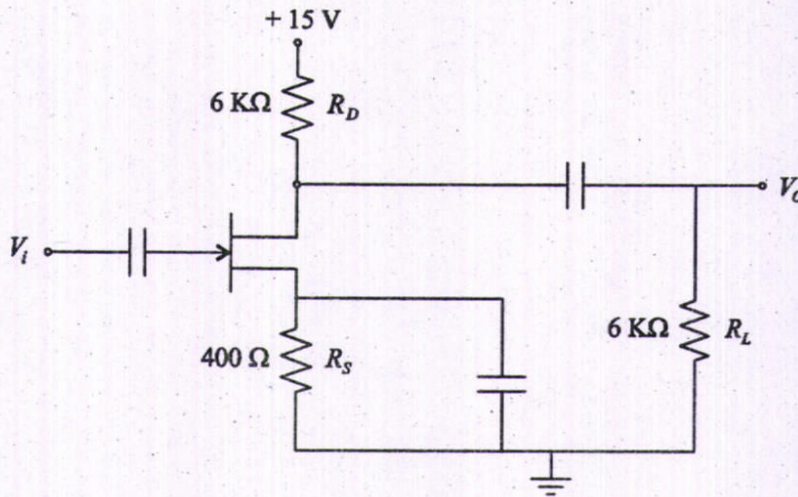

- In the given JFET as amplifier shown in the figure, the drain current changes from 4 mA to 6 mA when the gate voltage is changed from -3.8 V to -3.5 V in the amplifier circuit. Calculate the voltage gain of the amplifier. 12
- Explain the Barkhausen criterion for an oscillator circuit. How will the oscillator circuit's performance be affected if the Barkhausen criterion falls below 1, or goes much above 1? 8

- 8.(a) (i) Write a program in any programming language to sum of the following series up to N terms :
- $$|1| + |2| + |3| + |4| + |5| + \dots + |N|,$$
- where $|N| = \text{factorial of } N$. 10

- A company wishes to transmit numerous 10,000 bytes files between two computer systems connected through a computer network. Each byte consists of 8 data bits, no parity bits used in this application. Error is not a factor for transmission. What is the overhead percentage if a single file is sent asynchronously? What is the overhead percentage if the file is sent synchronously using blocks with 1000 data bytes in each block and each block is accompanied by 15 special bytes? Assume in asynchronous communication 1 start bit and 2 stop bits sent with each data byte. Comment, which transmission method is most efficient. 10

8.(b)

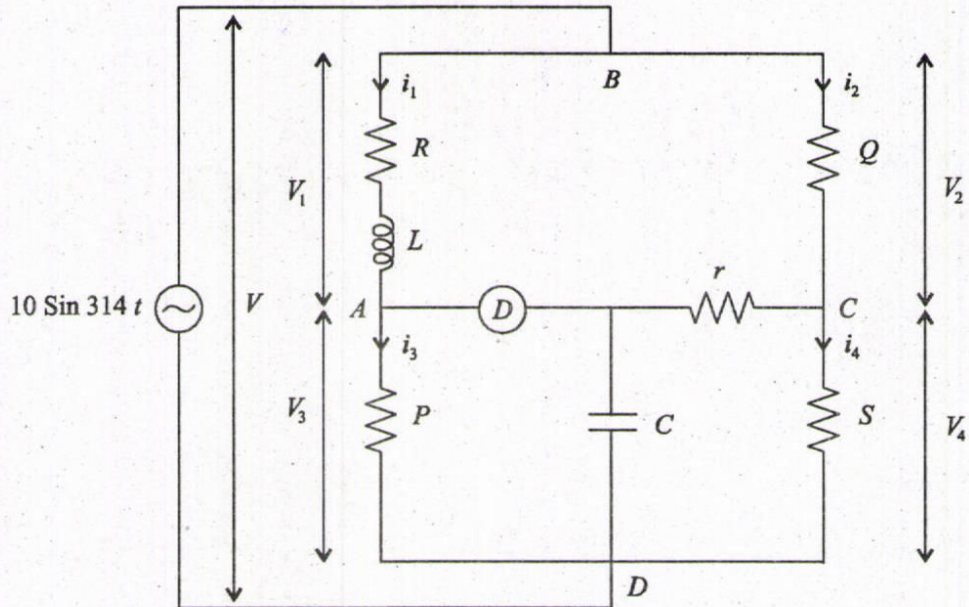

The bridge network shown in the figure measures the inductance (L) and resistance (R) if the impedance between A and B is unknown.

- (i) Find R and L if bridge balance is obtained for $Q = S = 1000 \Omega$, $P = 100 \Omega$, $r = 50 \Omega$, $C = 1 \mu F$.
- (ii) Draw the vector diagram showing the voltage and current at every point of the network.

20

8.(c)

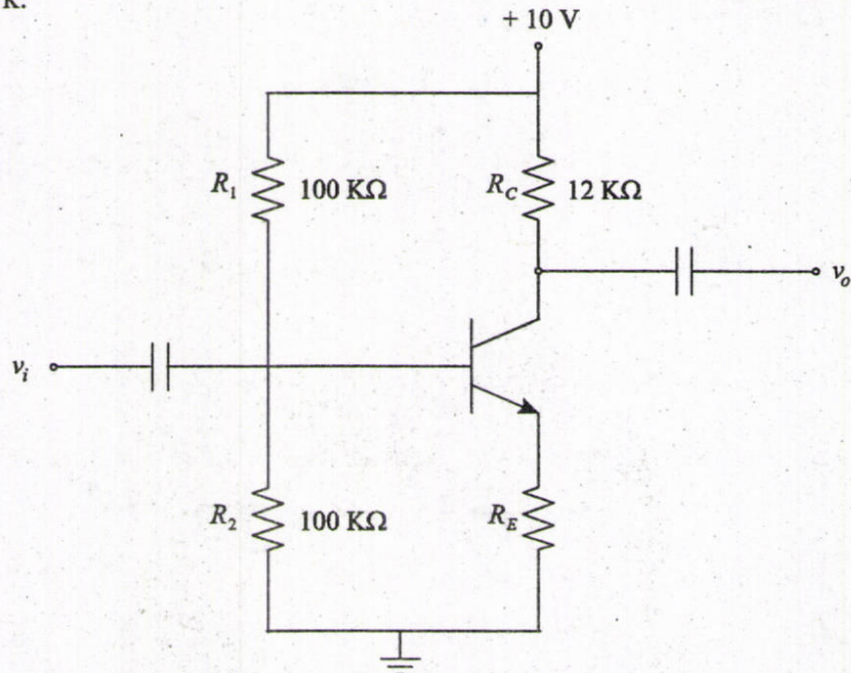

- (i) Common emitter (CE) amplifier shown in the figure has voltage gain 400 when $R_E = 0$. Stability is brought through negative feedback by adding resistor R_E . Find the value of resistor R_E using feedback concepts so that final voltage gain is equal to 200. 10
- (ii) Not all "zener" diodes breakdown in the exact same manner. Some operate on the principle of zener breakdown, while other operate on the principle of avalanche breakdown. How do the temperature coefficients of these two zener diode types compare? Are you able to discern whether a zener diode uses one principle or the other just from its breakdown voltage rating? Justify your answer. 10