

Sl. No. : TTTT

ಒಟ್ಟು ಪ್ರಶ್ನೆಗಳ ಸಂಖ್ಯೆ : 6 ]

**CCE RF**

[ ಒಟ್ಟು ಮುದ್ರಿತ ಪುಟಗಳ ಸಂಖ್ಯೆ : 4

Total No. of Questions : 6 ]

[ Total No. of Printed Pages : 4

ಸಂಕೇತ ಸಂಖ್ಯೆ : **72**

**Code No. : 72**

ಇಲ್ಲಿಂದ ಕತ್ತರಿಸಿ

ವಿಷಯ : ಇಂಜಿನಿಯರಿಂಗ್ ಗ್ರಾಫಿಕ್ಸ್ - 2

**Subject : ENGINEERING GRAPHICS - 2**

( ಹೊಸ ಪಠ್ಯಕ್ರಮ / New Syllabus )

( ಶಾಲಾ ಅಭ್ಯರ್ಥಿ / Regular Fresh )

ದಿನಾಂಕ : 24. 03. 2018 ]

[ Date : 24. 03. 2018

ಸಮಯ : ಮಧ್ಯಾಹ್ನ-2-00 ರಿಂದ 5-15 ರವರೆಗೆ ] [ Time : 2-00 P.M. to 5-15 P.M.

ಪರಮಾವಧಿ ಅಂಕಗಳು : 50 ]

[ Max. Marks : 50

**General Instructions to the Candidate :**

1. This Question Paper consists of 6 subjective types of questions.
2. This question paper has been sealed by reverse jacket. You have to cut on the right side to open the paper at the time of commencement of the examination. Check whether all the pages of the question paper are intact.
3. Follow the instructions given against both the objective and subjective types of questions.
4. Figures in the right hand margin indicate maximum marks.
5. The maximum time to answer the paper is given at the top of the question paper. It includes 15 minutes for reading the question paper.

TEAR HERE TO OPEN THE QUESTION PAPER

ಪ್ರಶ್ನೆ-ಪತ್ರಿಕೆಯನ್ನು ತೆರೆಯಲು ಇಲ್ಲಿ ಕತ್ತರಿಸಿ

Tear here

**RF-206**

[ Turn over

- Instructions :*
- i) Answer *all* the questions.
  - ii) Retain the constructional details.
  - iii) All dimensions are in mm.
  - iv) Use first angle projection only.
  - v) Missing dimensions may be assumed.
  - vi) All drawings should be drawn in drawing sheet only.

1. Draw the symbolic representation of first and third angle projection. 5
2. With a neat sketch show the proportions and angle of the following threads :
  - a) Square thread
  - b) Acme thread. 5
3. A right regular pentagonal prism of base edge 25 mm and 55 mm height rests on an edge of its base in H.P. such that its axis is parallel to V.P. and inclined to the H.P. at 45°. Draw the projections of the solid. 10
4. Draw isometric view of a hexagonal prism with side of base 25 mm and 60 mm long axis. The prism is resting on its base on H.P. with an edge of the base parallel to the V.P. 10
5. The pictorial view of an object is shown in figure No. 1. Draw the following orthographic views and mark the dimensions : 10
  - i) Front view — looking in the direction of arrow 'X'
  - ii) Top view — looking in the direction of arrow 'Y'
  - iii) Side view — looking in the direction of arrow 'Z'.

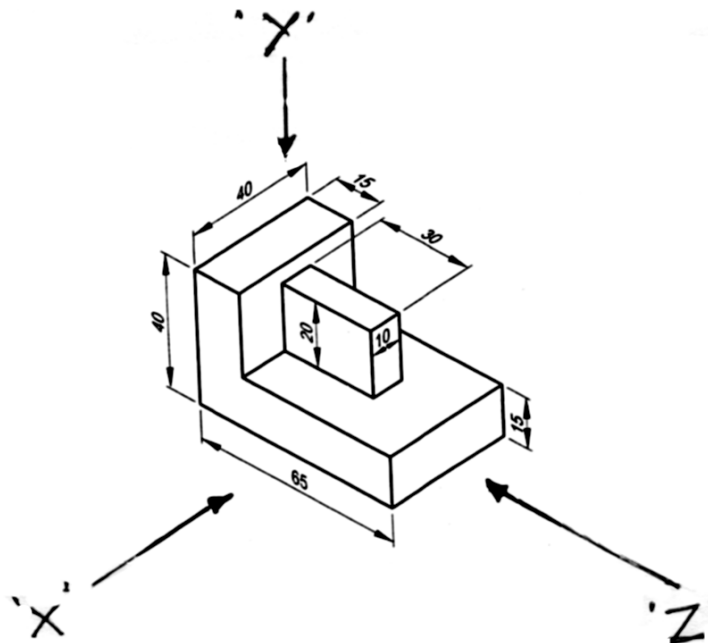

**Figure No. 1**



[www.careerindia.com](http://www.careerindia.com)